

# AST Trailer

## AERIAL SPLICING TRAILER



**43'4" Aerial  
Working Height**

**SPACIOUS 8' X 10' SPLICING LAB**



### DESIGN

Self-contained equipment package  
DC powered aerial charged by generator  
Security on the job

### ENVIRONMENTALLY RESPONSIBLE

No truck engine idle  
Ecothrottle generator  
Reduces fuel consumption  
Reduces noise pollution  
CARB Compliant



AST TRAILER

THIS DOCUMENT



**888-765-3322**

821 Enterprise, Hewitt, TEXAS 76643



**UTECH.SITE/ast**  
WEBSITE ADDRESS

## SPECIFICATIONS

GVWR	10,000 lbs
Trailer Weight	8,960 lbs *
Trailer Payload	1,040 lbs
Trailer Length	21.4 ft
Tongue Weight	1,500 lbs *
* approximate weight	

## SPLICING LAB

Interior Body Height	6 ft 2 in (1.8 m)
Cargo Space of 505 cu/ft of Usable Space	
Full-Service Mobile Workshop w/Walk-In Height	
Insulation in Walls & Floor	
AC & Heat	
Full Length Splicing Table	
Splicing Doors (Qty 2)	
Full Height Drawer Set	
Cabinet Storage	
DOT Lighting	
Amber Strobes	
Exterior Work Lights	

## AERIAL SPECIFICATIONS

Horizontal Side Reach	25 ft 6 in (7.77 m)
Height Bottom Basket*	38 ft 4 in (11.4 m)
Working Height*	43 ft 4 in (13.20 m)
Stowed Height*	12 ft 3 in (3.7 m)
Standard Basket Capacity	350 lbs (159 kg)
540 Degree Rotation	
24 VDC Powered Aerial - std.	
Electric Tool Outlet at Basket	
Emergency Lower 12 VDC	
Proportional Upper Controls w/ Single Handle Actuator	
Side Mounted Walk-Thru Basket w/ Door	
Lightweight Aluminum Inner Boom	
Hydraulic Leveling Basket	
Pedestal Riser Houses Hydraulic Reservoir and Batteries	
UTLN41 meets and exceeds ANSI A92.9-2015 and OSHA Requirements	
*Based on a 35 in (0.89m) pickup bed height	

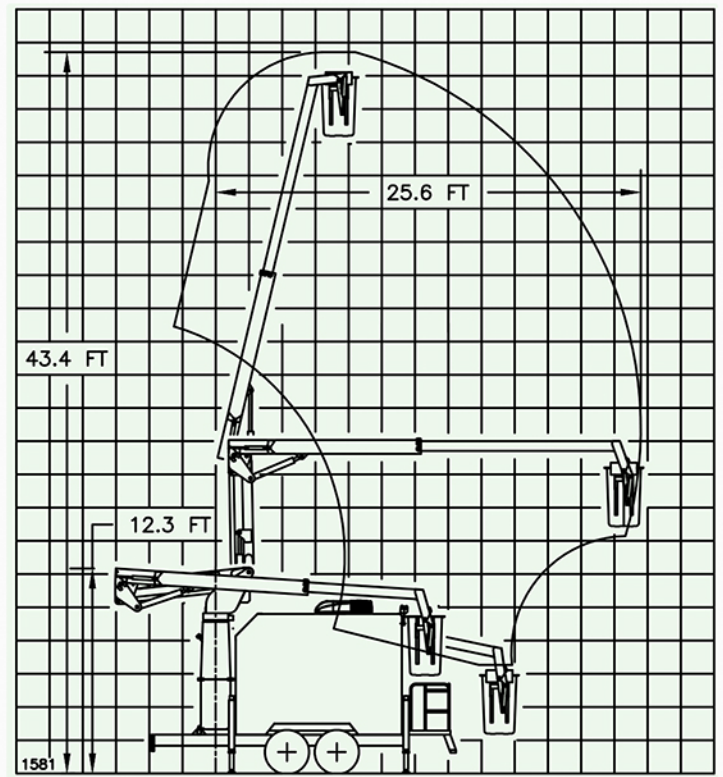

**UTECEQUIP.COM**

**888-765-3322**

821 Enterprise, Hewitt, TEXAS 76643