

ARP truck

UTLI35 INSULATED

UTLN35 NON-INSULATED

AERIAL READY PICKUP

Working Height **33' 1" (10.08m)***

Horizontal Reach **19' 9" (6.01m)***

Basket Capacity **350 lbs (159kg)**

* dimensions vary according
to model number and
options

Easy to use!



VEHICLE

- Optional Tool Boxes
- Truck warranty 36 mos or 36,000 miles
- Low aerial maintenance cost
- User friendly - Drives like a pickup!
- Pull your trailer to the jobsite
- Simple operation
- Service multiple jobs w/o transport costs
- Simple intuitive operation
- 2WD or 4WD
- Single rear wheel
- No outriggers

APPLICATIONS

- Tree Trimming / Landscape
- Electrical (Insulated Boom Available)
- Telecommunications
- Framing & Painting
- General Contractors
- Home Owners
- Lighting
- Maintenance
- Surveillance

1-888-765-3322



Utility Truck Equipment Co, L.L.C.

901 Enterprise Blvd

Hewitt, Texas 76643

Phone: 254-857-8204 Fax: 254-857-9253

www.UTECequip.com

ARP truck

UTLI35

UTLN35

INSULATED

NON-INSULATED

AERIAL READY PICKUP

AERIAL SPECIFICATIONS

- Horizontal Side Reach 19' 9" (6.02m)
- Height Bottom Basket 28' 1" (8.56m)
- Working Height 33' 1" (10.08m)
- Stowed Height 10' 3" (3.12m)
- Standard Basket Capacity 350 lbs (158.76kg)
- 540 Degree Rotation
- Engine Driven Hydraulic Pump
- Emergency Lowering 12 VDC
- Proportional Upper Controls w/ Single Handle Actuator
- Side Mounted Walk-Thru Basket w/ Door
- Light Weight Aluminum Inner Boom
- Hydraulic Leveling Basket
- Pedestal Houses Hydraulic Reservoir and 12VDC Motor

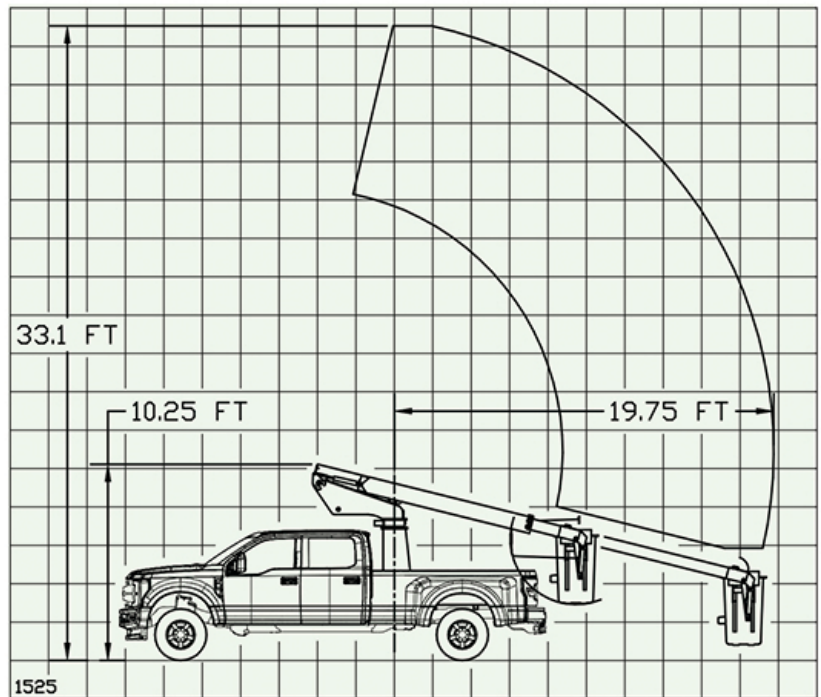

PICKUP REQUIREMENTS



- Pickup GVWR* 10,000 lbs
- Front Axle GAWR* 3,950 lbs
- Rear Axle GAWR* 6,340 lbs
- Approx Weight for Stability 7,800 lbs
- Bed Length 8 ft
- Single or Dual Rear Wheels

*Based on minimum specifications



UTLN35A meets and exceeds ANSI A92.2-2015 and OSHA Requirements

*Based on a 35in frame height



1-888-765-3322



Utility Truck Equipment C6 L.L.C.
901 Enterprise Blvd
Hewitt, Texas 76643
Phone: 254-857-8204 Fax: 254-857-9253
www.UTECEquip.com

THIS DOCUMENT

